

TUJPAI®

PARTNER IN SMART SOLUTIONS

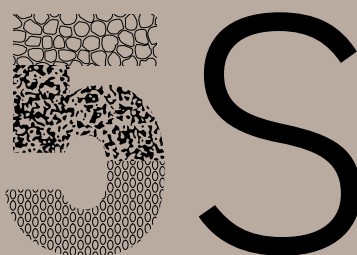
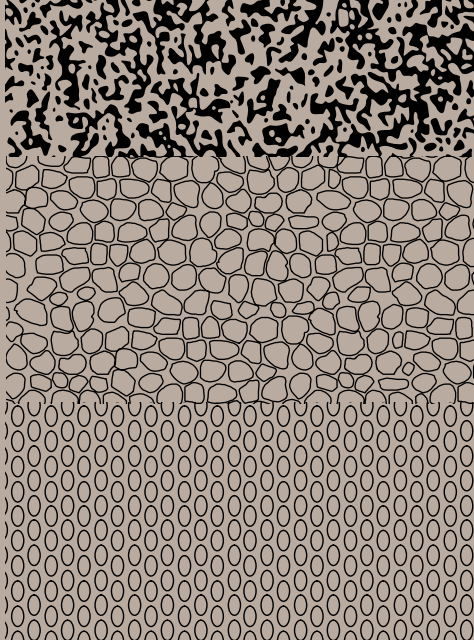

TEXTURE

TUPAI.PT

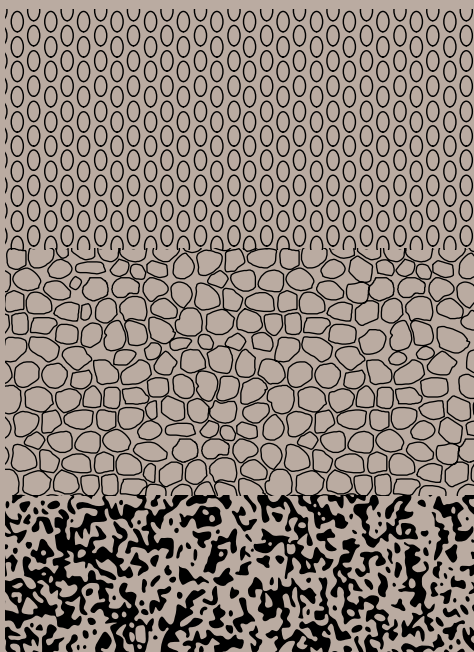

TUPAI®

BACK TO NATURE

BACK TO OURSELVES



Ponto de encontro: o lugar seguro.

Contacto lá fora, cá dentro. Uma nova forma de ser, um novo alento. O recolhimento, o espaço interior, bem cá dentro onde tudo muda constantemente.

Um toque delicado, com os 5 sentidos bem despertos.

Um tempo que exige crescimento, adaptação e inspiração.

O tempo onde tudo mudou, onde cooperamos com os ciclos e com as voltas que o mundo dá.

Passaram 45 anos e voltamos a este lugar.

Este é um convite para um mundo de renovação.

A busca das melhores matérias-primas e camadas do que está por descobrir. O desafio de conexão diário, de pés na terra e olhos no céu. De contacto com os outros, com a natureza e, sobretudo, com os espaços memoráveis e confortáveis que habitamos. Este é o nosso desafio aceite todos os dias.

Meeting point: the safe place.

Contacting outside, inside. A new way of being, a new breath. The retreat, the interior space, right inside us where everything changes constantly.

A delicate touch, with all 5 senses wide awake.

A time that requires growth, adaptation and inspiration.

The time where everything changed, where we cooperate with the cycles and turns that the world takes.

45 years pass and we return to this place.

This is an invitation to a world of renewal.

The search for the best raw materials and layers of what is yet to be discovered. The daily connection challenge, feet on earth and eyes in heaven. In contact with others, with nature and, above all, with the memorable and comfortable spaces we inhabit. This is the challenge we accept daily.

INSIDE – OUTSIDE
THE WORLD, A NEW SAFE PLACE TO BE

TUPAI

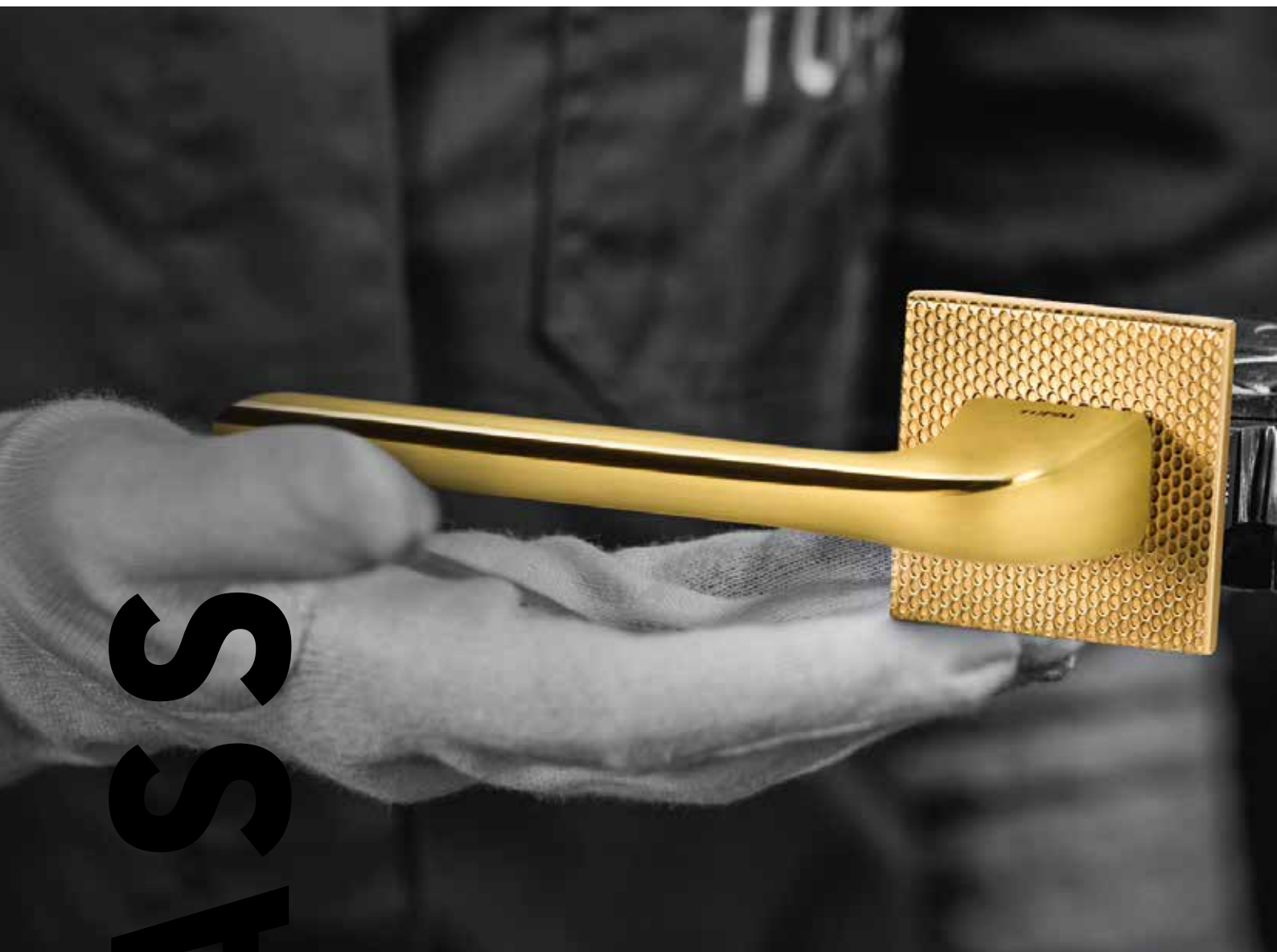

BRASS

45 YEARS
ANOS



SINCE
DESDE **1976**



BACK TO BRASS

THE TEXTURE PIONEERS

Latão: matéria-prima e tradição.

Ponto de equilíbrio onde o polimento manual e a combinação de texturas orgânicas refletem o cuidado e o detalhe deste novo passo. Abrir caminho é também ampliar a visão e chegar a novas combinações improváveis. Nisso também somos pioneiros. Aqui os acabamentos prestigiantes convidam à fusão com a natureza e à celebração de mais de quatro décadas de crescimento.

Brass: raw material and tradition.

Balance point where manual polishing and the combination of organic textures reflect the care and detail of this new step. Opening a path is also broadening the vision and come up with unlikely new combinations. We are also pioneers in this. Here, the prestigious finishes invite you to merge with nature, celebrating more than four decades of growth.

TUPAI®



NATURE INSIDE

A linha curva, as formas orgânicas e elementares.
O paradoxo que reúne a simplicidade e a complexidade,
os contrastes que abrem a porta ao sentir.

Natureza: o ponto de partida.

The curved line, organic and elementary forms.
It's paradoxical, brings together simplicity and complexity,
the contrasts that open the door to feeling.

Nature: the starting point.

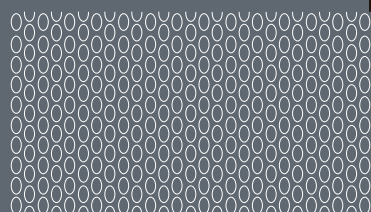

INSPIRED BY NATURE
TOUCHED BY EARTH

5S TEXTURE

Textura: camada superficial,
matéria-prima esculpida pela natureza.
Inspirada na sua beleza, detalhes e qualidades únicas,
esta gama resulta num conjunto de peças
naturalmente sensoriais e estimulantes.

Texture: surface layer,
raw material carved by nature.
Inspired by its beauty, details and unique qualities,
this range results in a set of handles,
naturally sensory and stimulating.

TEXTURE



TUPAI®

T2 WATERFALL

3 TEXTURES

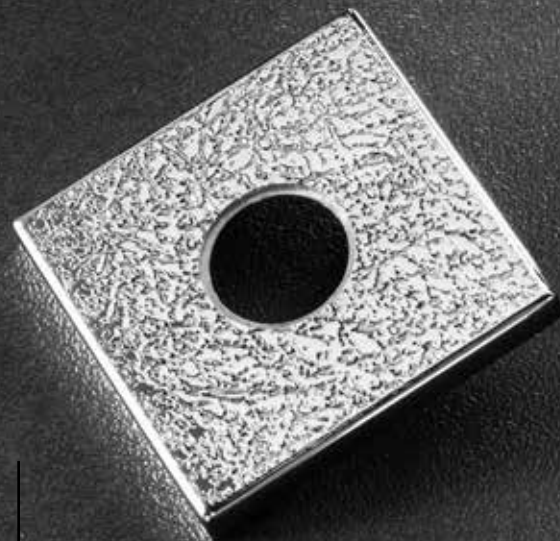
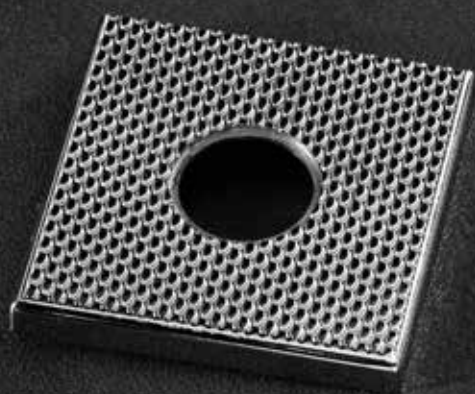

T3 LEATHER

T1 PEBBLES

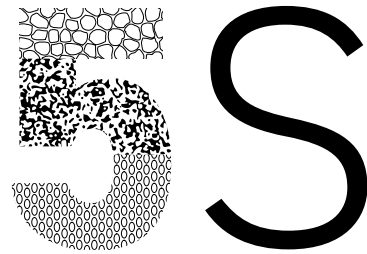

TEXTURE

Design único com um caráter distinto.

Inspirada na natureza, esta gama oferece um toque inconfundível com uma combinação perfeita de formas curvas e geométricas.

One of a kind design with a distinct character.

Inspired by nature, this range offers a unique touch with a perfect blend of curvy and geometric shapes.

TUPAI.PT

TUPAI®



0 4220 5SQ T1
4220 5SQ T2
4220 5SQ T3

1 4230 5SQ T1
4230 5SQ T2
4230 5SQ T3

2 4240 5SQ T1
4240 5SQ T2
4240 5SQ T3

4161 5SQ

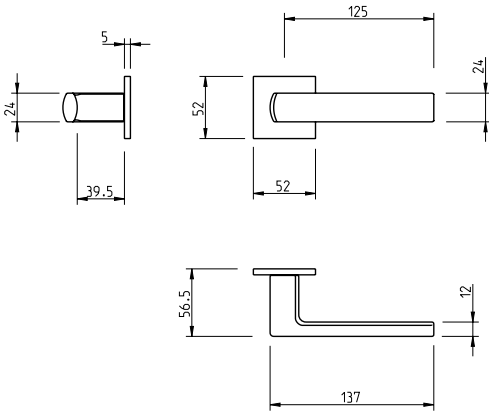

Puxador par
Adaptador metálico com sistema "click"
Mola recuperadora reversível
Ferro quadrado de 8x90mm
Fixação da muleta com parafuso M6 oculto

Lever set
Metallic mechanism with "click" system
Reversible recovery spring
8x100mm square spindle
Handle fixed by a M6 grub screw



T3 LEATHER

A textura orgânica do mundo natural, um micro-organismo, camuflado ou exposto num produto que ganha uma nova vida.

The organic texture of the natural world, a microorganism, camouflaged or exposed in a product that gains a new life.



(03)
cromado brilhante
bright chrome

T1
PEBBLES



T2
WATERFALL



T3
LEATHER

(03)
cromado brilhante
bright chrome

(33)
latão polido /satinado
polished/satin brass

(77)
bronzado mate
mate antique brass

(153)
preto pérola
black pearl

TUPAI[®]



0 4220 5SQ T1
4220 5SQ T2
4220 5SQ T3

4230 5SQ T1
4230 5SQ T2
4230 5SQ T3

4240 5SQ T1
4240 5SQ T2
4240 5SQ T3

4165 5SQ

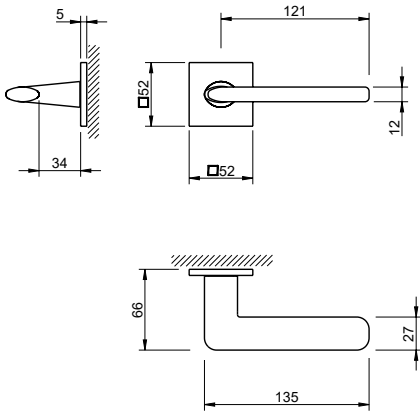

Puxador par
Adaptador metálico com sistema "click"
Mola recuperadora reversível
Ferro quadrado de 8x90mm
Fixação da muleta com parafuso M6 oculto

Lever set
Metallic mechanism with "click" system
Reversible recovery spring
8x100mm square spindle
Handle fixed by a M6 grub screw

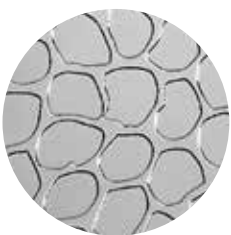

T1 PEBBLES

A irregularidade das pedras esculpidas pela água e pelo vento, a pele que protege o corpo e nos remete para um estilo elegante com um toque de exuberância.

The irregularity of stones carved by water and wind, the skin that protects the body and reminds us of an elegant style with a touch of exuberance.



(03)
cromado brilhante
bright chrome

T1
PEBBLES



T2
WATERFALL



T3
LEATHER

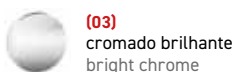

(03)
cromado brilhante
bright chrome



(33)
latão polido / satinado
polished/satin brass

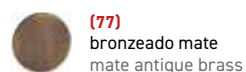

(77)
bronzeado mate
mate antique brass

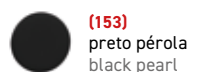

(153)
preto pérola
black pearl

TUPAI



0 4220 5SQ T1
4220 5SQ T2
4220 5SQ T3

1 4230 5SQ T1
4230 5SQ T2
4230 5SQ T3

2 4240 5SQ T1
4240 5SQ T2
4240 5SQ T3

4007 5SQ

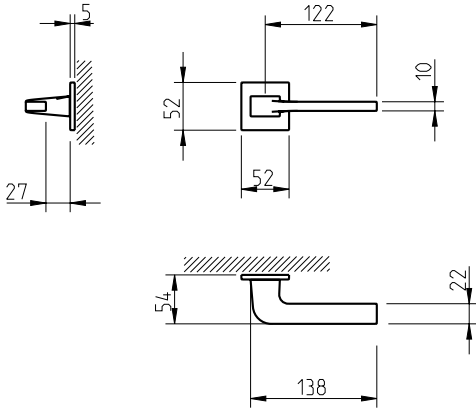

Puxador par
Adaptador metálico com sistema "click"
Mola recuperadora reversível
Ferro quadrado de 8x90mm
Fixação da muleta com parafuso M6 oculto

Lever set
Metallic mechanism with "click" system
Reversible recovery spring
8x100mm square spindle
Handle fixed by a M6 grub screw



(03)
cromado brilhante
bright chrome

T1
PEBBLES



T2
WATERFALL



T2 WATERFALL

Inspirada nas cascatas e nas gotas de orvalho das manhãs, esta textura confere personalidade a uma vasta tipologia de ambientes.

Inspired by waterfalls and morning dew drops, this texture gives personality to numerous environments.



T3
LEATHER

(03)
cromado brilhante
bright chrome

(33)
latão polido /satinado
polished/satin brass

(77)
bronzado mate
mate antique brass

(153)
preto pérola
black pearl

TUPAI®



0 4220 5SQ T1
4220 5SQ T2
4220 5SQ T3

4230 5SQ T1
4230 5SQ T2
4230 5SQ T3

4240 5SQ T1
4240 5SQ T2
4240 5SQ T3

4002 5SQ

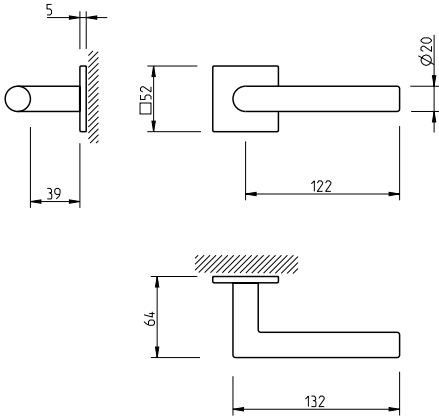

(153)
preto pérola
black pearl

T1
PEBBLES

Puxador par
Adaptador metálico com sistema "click"
Mola recuperadora reversível
Ferro quadrado de 8x90mm
Fixação da muleta com parafuso M6 oculto

Lever set
Metallic mechanism with "click" system
Reversible recovery spring
8x100mm square spindle
Handle fixed by a M6 grub screw



T2
WATERFALL



T3 LEATHER

Uma nova possibilidade de valorizar o latão as suas aplicações e características únicas. O contraste entre a rugosidade e o acabamento de um polimento manual.

A new possibility to value brass for its unique applications and characteristics. The contrast between the roughness and the manual polishing finish.



T3
LEATHER

(03) cromado brilhante
bright chrome

(33) latão polido /satinado
polished/satin brass

(77) bronzeado mate
mate antique brass

(153) preto pérola
black pearl

4220 5SQ

Espelho chave par
Adaptador metálico

Key entry set
Metallic adapter

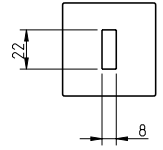
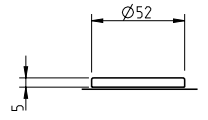

T1
PEBBLES

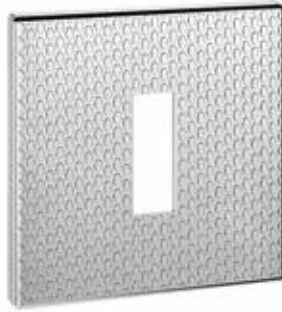

T2
WATERFALL

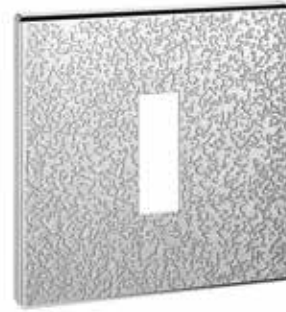

T3
LEATHER

4230 5SQ

Espelho chave par
Adaptador metálico

Key entry set
Metallic adapter

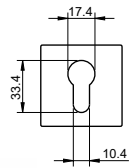
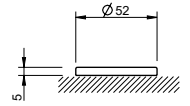

T1
PEBBLES



T2
WATERFALL



T3
LEATHER

 (03)
cromado brilhante
bright chrome

 (33)
latão polido /satinado
polished/satin brass

 (77)
bronzado mate
mate antique brass

 (153)
preto pérola
black pearl

4240 5SQ

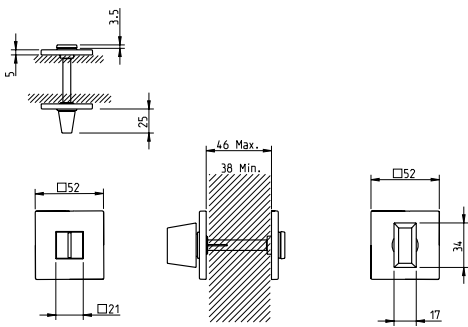

Conjunto de botão WC

WC button set



T1
PEBBLES



T2
WATERFALL



T3
LEATHER

TUPAI



(03)
cromado brilhante
bright chrome



(33)
latão polido /satinado
polished/satin brass



(77)
bronzado mate
mate antique brass



(153)
preto pérola
black pearl

TUPAI®



WE CARE

ABOUT BRASS AND TEXTURE
CUIDADOS PARA PRODUTOS
DE LATÃO TEXTURADOS

CUIDADOS DE LIMPEZA

CLEANING AND CAUTIONS

CUIDADOS PARA PRODUTOS DE LATÃO

Para manter a qualidade dos nossos produtos, certifique-se que para remover manchas ou impressões digitais, deve apenas utilizar um pano húmido com detergente neutro.

A acumulação de resíduos pode causar descoloração do acabamento original. Para evitar tais danos, limpe os produtos com um pano húmido e seque completamente. Recomenda-se que esta limpeza seja feita regularmente e incorporada na rotina geral de limpeza.

Não use solventes fortes, produtos de limpeza abrasivos ou esfregões em qualquer um dos nossos produtos. Isso pode afetar a espessura dos revestimentos de proteção, como revestimento, pintura e verniz.

Não use álcool desnaturado em qualquer produto com acabamento em latão, pois pode remover qualquer revestimento estético ou protetor.

NÃO USAR:

- produtos abrasivos
- esfregões
- produtos de limpeza para prata ou latão
- produtos com álcool

CARING FOR BRASS PRODUCTS

To maintain the superior finish of our design doorware products, please ensure that only a damp cloth is used with diluted, mild detergent to remove any stains or fingerprints.

Residue build-up may cause discolouration of the original finish. To avoid such damage, please wipe products with a damp cloth, and dry thoroughly. It is recommended that this be done regularly, and incorporated into a general cleaning routine.

Do not use harsh solvents, abrasive cleaners or scourers on any of our designer doorware's products. This may affect the thickness of protective coatings, such as plating, painting and lacquer.

Do not use methylated spirits on any product with a brass or antique finish, as it may strip away any aesthetic or protective coating. Likewise, painting and lacquered finishes should be cleaned only with a damp cloth and mild detergent.

DO NOT USE:

- coarse abrasive powders
- metallic scourers
- silver or brass cleaners
- alcohol based products

MONTAGEM

ASSEMBLY



WATCH VIDEO
VER VÍDEO

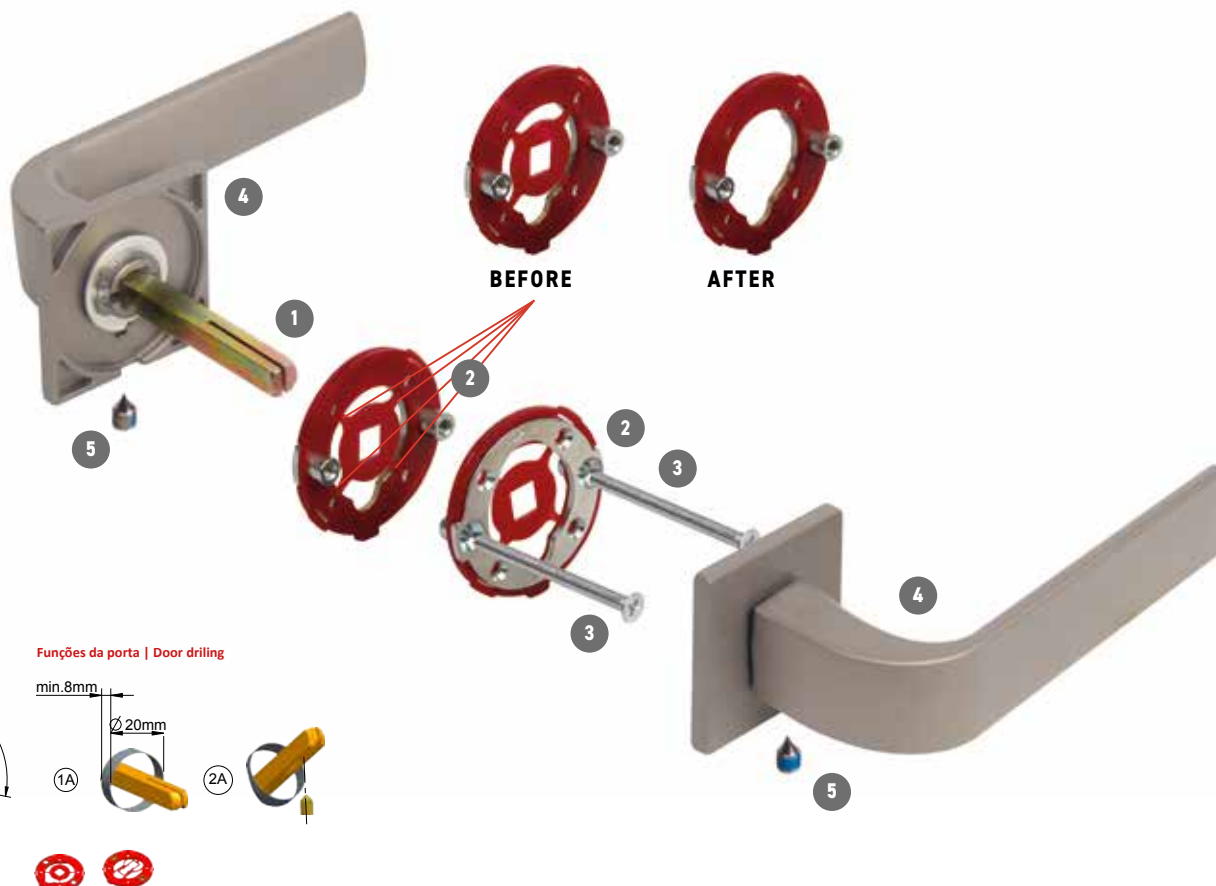

Funções da porta | Door drilling

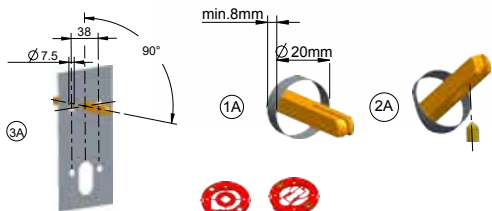

NOTA: Existe opção sem postes.
NOTE: With or without embedded fittings in the door.

INSTRUÇÕES

- 1 Colocar o ferro 8mm (1) na porta (com a ranhura mais larga virada para baixo) conforme fig. 2A
- 2 Colocar o adaptador (2) com parafusos passantes (3)
- 3 Partir e limpar o interior plástico quadrado nos dois adaptadores. O interior da peça plástica deve ser removido
- 4 Aplicar o puxador (4) com o espelho de baixo para cima, ajustar e pressionar de encontro com a porta fazendo o "CLICK"
- 5 Apertar os pernos roscado M6 de encontro ao ferro 8mm

INSTRUCTIONS

- 1 Position the 8 mm square spindle (1) in the door (wider groove facing down) according fig. 2A
- 2 Fix the adapter plates (2) to the door with the passing/wooden screws (3)
- 3 Inserting the handle (4) and twisting, break the inside plastic part of the adapter plate. Don't forget to remove it afterwards
- 4 Adjust the handle rosette to the adapter with a bottom to top pushing movement until it "clicks"
- 5 Tighten the M6 threaded pins (5) on the handle against the square spindle

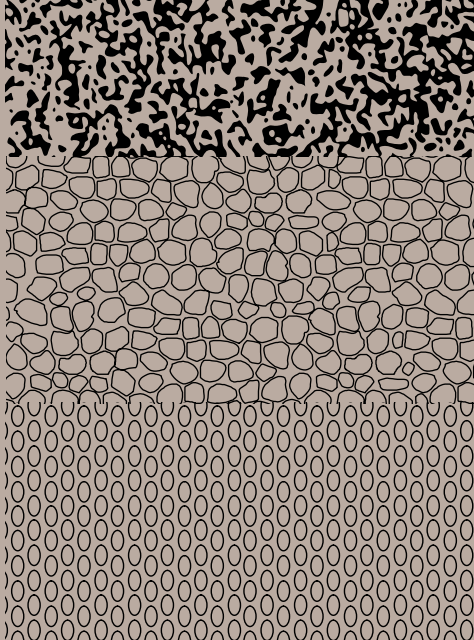

TUPAI
RASO DE PAREDES AP. 3099
3754-901 ÁGUEDA, PORTUGAL
GPS N 40.585824 W 8.465514

TEL. +351 234 612 600
FAX +351 234 601 295

TUPAI @TUPAI.PT

WWW.TUPAI.PT



DMKT 2021

Cofinanciado por:

